

Overview

A stand-alone, or Networked Fan/Blower Phase Control for use with Single-Phase Permanent Split capacitor (PSC) or Shaded-Pole Induction Motors. Capable of 3.0 or 4.0 ampere in 115, 230, or 277 volt models, these controls offer a 3-wire or 2-wire connection option. Open-loop or Closed-loop operation are selectable in these controllers. AirCare VariPhase™ has network connectivity (MODBUS® RTU-based) through RJ45 to our Small System Console.

PRODUCT DESCRIPTION

AirCare VariPhase™ controls combine intelligent speed control with industry standard MODBUS® networking. The versatile design allows for either analog (0-5V or 20mA), loop or network speed control. In network mode VariPhase™ units can have up to 125 unique addresses that can be precisely controlled from a single AirCare Console™. Consoles are designed to handle from 10 to 125 VariPhase units per zone (consoles come with 1 to 4 zones).

For optimal efficiency and reduced acoustic noise, VariPhase™ models include intelligent auxiliary winding control using a 3rd wire to the motor. Soft-start options are also available. Permanent Split Capacitor (PSC) motor loads can be connected in three-wire mode or wired conventionally for standard operation.

VariPhase's™ speed regulation control capability utilizes an external hall-effect sensor to precisely control and monitor fan speed. An internal PID controller uses an external sensor to hold a set point.

VariPhase™ "Closed Loop Control" mode uses a second Analog Input (ANA2) allows for closed loop control of the speed to any controlled parameter that can provide a 0-5 volt feedback signal. The PID parameters can be adjusted to provide stable controlled operation.

Installing a distributed network of AirCare controls is simplified by flexible wiring options and diagnostic LEDs. AirCare can also be controlled from an analog signal source.

Electrical Parameters

Parameter	Min	Typical	Max
Input Voltage Range 115V unit	95V	115V	135V
Input Voltage Range 230V unit	200V	230V	260V
Input Voltage Range 277V unit	250V	277V	305V
Supply Frequency (Hz)		50/60 Hz	
Output Current (Arms) Continuous			See table
Output Current (Arms) 30 seconds			125%
Output Voltage (Vac)	0		V _{in}
Ambient Operating Temperature (°C)	0	25°C	40°C
Standby Supply Power		<2W	
Insertion Loss (V)		1V	2V
Control Power Loss (W)		1W/Amp	2W/Amp
Isolation Voltage (Vrms)	2500V		
Sensor Supply Voltage Output (Vdc)		5V/12V	
Sensor Supply Current Output (mA)			25mA

Pictured- 1041U-001 with optional Cover



Model Matrix

Model	Voltage Rating	Current Rating
ACV 1041U	115Vac	4.0A
ACV 1042U	230Vac	4.0A
ACV 1033U	277Vac	3.0A

Communications

- MODBUS® RTU Protocol
- Selectable wiring - RS422 (4 wire), or RS485(2 wire)
- Selectable baud rate- 1200 or 9600, 8 n, 1
- Dual RJ45 sockets (2 and 4 wire) for communication
- Field selectable addressing
- Supports up to 127 devices per Network
- Slew rate control for improved performance

Features

- 3-wire or 2-wire control
- Automatic 50Hz or 60Hz
- Soft-Start (adjustable) enabled
- "Speed set memory" resets to last setting under power loss
- Open Loop Analog Control input (0-5Vdc, 0, 4-20mA)
- Closed Loop Control to external Sensor (i.e. pressure, temperature) to regulate fan speed to external (0-5 volt feedback) criteria
- Speed Regulation option (external hall sensor feedback)
 - Measures and controls actual speed
- Open-frame (UL approved, NEMA 1 cover optional)
- Diagnostic LED's:
 - Status/Fault
 - Network Traffic
- Overload: 125% for 30 seconds
- Analog PID controller for closed-loop sensor operation

Jumper Options:

JP1	JP2	JP3	JP4	JP5	JP6
Analog	20mA	Baud	4-20mA	Closed Loop	4-wire

- Analog** - Install jumper to select analog input speed control from either 0-5V or 4-20mA source. When jumper position is open, the control responds to Modbus speed commands.
- 20mA** - Install jumper to enable current loop shunt. JP1 should also be closed to enable 4-20mA control. Leave switch open for 0-5V control.
- Baud** - Install jumper to select 9600 board. Default is 1200.
- 4-20mA** - Install jumper to enable 4-20mA loop. If jumper position is open the 4mA offset will not be factored, resulting in 0-20mA control range.
- Speed Control** - The sensor will be used to regulate the set speed in RPM. If jumper position is open, the sensor input will not be used for motor speed control, but RPM will still be reported as if a sensor is present.
- 4-wire** - Fit jumper to select 4-wire (RS422) communication. Default (jumper open) is 2 wire (RS485) communication.

Mechanical Dimensions:

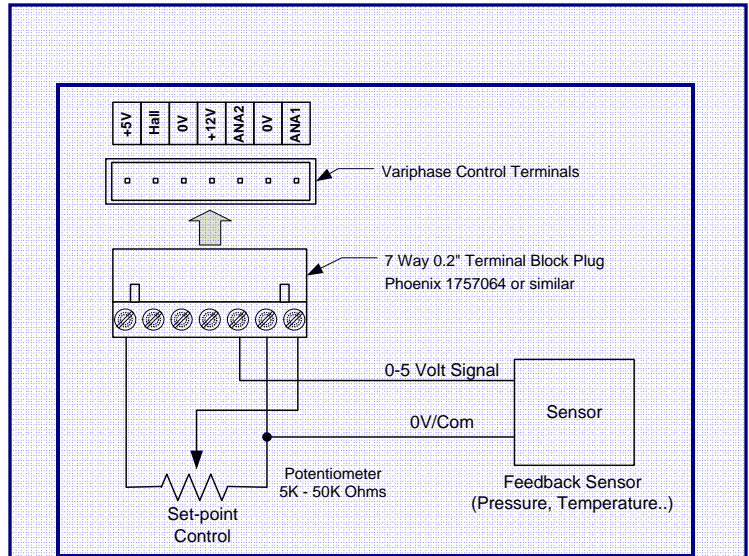
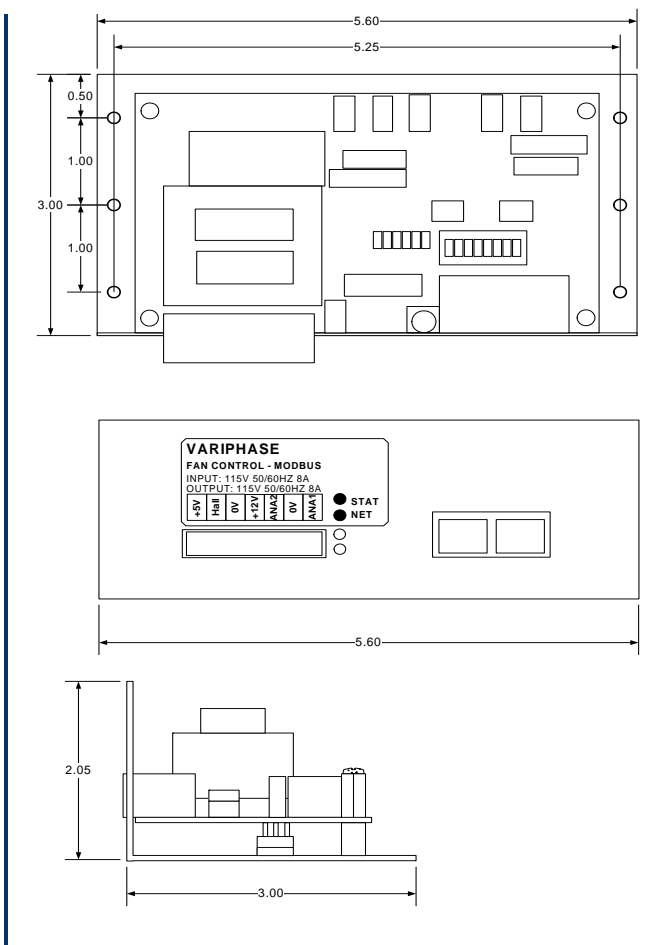

Control Wiring Example : Closed Loop Analog Control

In this mode Variphase™ uses a 0-5 Volt feedback signal from a sensor to hold a potentiometer-controlled set-point. The set-point can also be network controlled. Enabling and configuring Closed Loop control requires an AirCare ACC1-SP1 Console.

Control Connections

Mating part for control connector Phoenix terminal block number is #1757

1	2	3	4	5	6	7
+5V Out	Hall Sensor Signal	0V (GND)	+12V Out	Analog 2 Input	0V (GND)	Analog 1 Input

Power Connections

ML	AL	L	MN	N
Line in Motor	Line to Motor Aux	AV Line Input	Neutral to Motor	AC Neutral Input

