



V-SERIES

AirCare VariPhase™

ACV1081U
ACV1082U
ACV1083U

Overview

The AirCare VariPhase™ is a Network or Analog controlled Fan/Blower Control for use with Single-Phase Permanent Split capacitor (PSC) or Shaded-Pole Induction Motors. Capable of 8 ampere in 115, 230, and 277 volt models, these controls offer a 3-wire (higher efficiency and lower noise) or traditional 2-wire connection option. Open-loop or Closed-loop operation is selectable. AirCare VariPhase™ has network connectivity (MODBUS® RTU-based) through RJ45 to any controller or AirCares' Proprietary Control System. Analog Control input allows manual control or analog inputs from any PLC or system controller.



PRODUCT DESCRIPTION

AirCare VariPhase™ controls combine intelligent speed control with industry standard MODBUS® RTU networking. The versatile design allows for either analog (0-5V or 20mA) or network speed control. In network mode VariPhase™ units can have up to 125 unique addresses that can be precisely controlled from our proprietary AirCare Console™, AirCare system controller your PLC or Building Management System (BMS).

For optimal efficiency and reduced acoustic noise, VariPhase™ models include intelligent auxiliary winding control using a 3rd wire to the motor. Soft-start options are also available. Permanent Split Capacitor (PSC) motor loads can be connected in three-wire mode or wired conventionally for standard operation.

RPM speed regulation control utilizes an external hall-effect sensor (counter through "HALL" connection) to precisely control and monitor fan speed. An internal PID controller provides system loop stability customized for your system.

"Closed Loop Control" mode uses the second Analog Input (ANA2) that allows for closed loop control of the speed to any controlled parameter that can provide a 0-5 volt feedback signal. The PID parameters can be adjusted to provide stable controlled operation.

Installing a distributed network of AirCare controls is simplified by flexible wiring options and diagnostic LEDs.

Electrical Parameters

Parameter	Min	Typical	Max
Input Voltage Range 115V unit	95V	115V	135V
Input Voltage Range 230V unit	200V	230V	260V
Input Voltage Range 277V unit	250V	277V	305V
Supply Frequency (Hz)		50/60 Hz	
Output Current (Arms) Continuous			See table
Output Current (Arms) 30 seconds			125%
Output Voltage (Vac)	0		V _{in}
Ambient Operating Temperature (°C)	0	25°C	40°C
Standby Supply Power		<2W	
Insertion Loss (V)		1V	2V
Control Power Loss (W)		1W/Amp	2W/Amp
Isolation Voltage (Vrms)	2500V		
Sensor Supply Voltage Output (Vdc)		5V/12V	
Sensor Supply Current Output (mA)			25mA

Model Matrix

Model	Voltage Rating(AC)	Current Rating
ACV 1081U	115V	8.0A
ACV 1082U	230V	8.0A
ACV 1083U	277V	8.0A

Communications

- MODBUS® RTU Protocol
- Selectable wiring - RS422 (4 wire), or RS485(2 wire)
- Selectable baud rate- 1200 or 9600, 8 n, 1
- Dual RJ45 sockets (2 and 4 wire) for communication
- Field selectable addressing
- Supports up to 127 devices per Network
- Slew rate control for improved performance

Features

- 3-wire or 2-wire control
- Automatic 50Hz or 60Hz
- Soft-Start (adjustable) enabled
- "Speed set memory" resets to last setting under power loss
- Open Loop Analog Control input (0-5Vdc, 0, 4-20mA)
- Closed Loop Control to external Sensor (i.e. pressure, temperature) to regulate fan speed to external (0-5 volt feedback) criteria
- Speed Regulation option (external hall sensor feedback) -Measures and controls actual speed
- Open-frame (UL approved, NEMA 1 cover optional)
- Diagnostic LED's:
 - Status/Fault
 - Network Traffic
- Overload: 150% for 30 seconds
 - Analog PID controller for closed-loop sensor operation

Email: info@aircareautomation.com
8204 N. Lamar, Suite B-11 Austin, TX 78753.

Website: www.aircareautomation.com
Tel: (512)249-7526 Fax: (512)275-6155

Jumper Options:

JP1	JP2	JP3	JP4	JP5	JP6
Analog	20mA	Baud	4-20mA	Closed Loop	4-wire

- Analog** - Install jumper to select analog input speed control from either 0-5V or 4-20mA source. When jumper position is open, the control responds to Modbus speed commands.
- 20mA** - Install jumper to enable current loop shunt. JP1 should also be closed to enable 4-20mA control. Leave switch open for 0-5V control.
- Baud** - Install jumper to select 9600 board. Default is 1200.
- 4-20mA** - Install jumper to enable 4-20mA loop. If jumper position is open the 4mA offset will not be factored, resulting in 0-20mA control range.
- Speed Control** - The sensor will be used to regulate the set speed in RPM. If jumper position is open, the sensor input will not be used for motor speed control, but RPM will still be reported as if a sensor is present.
- 4-wire** - Fit jumper to select 4-wire (RS422) communication. Default (jumper open) is 2 wire (RS485) communication.

Mechanical Dimensions:

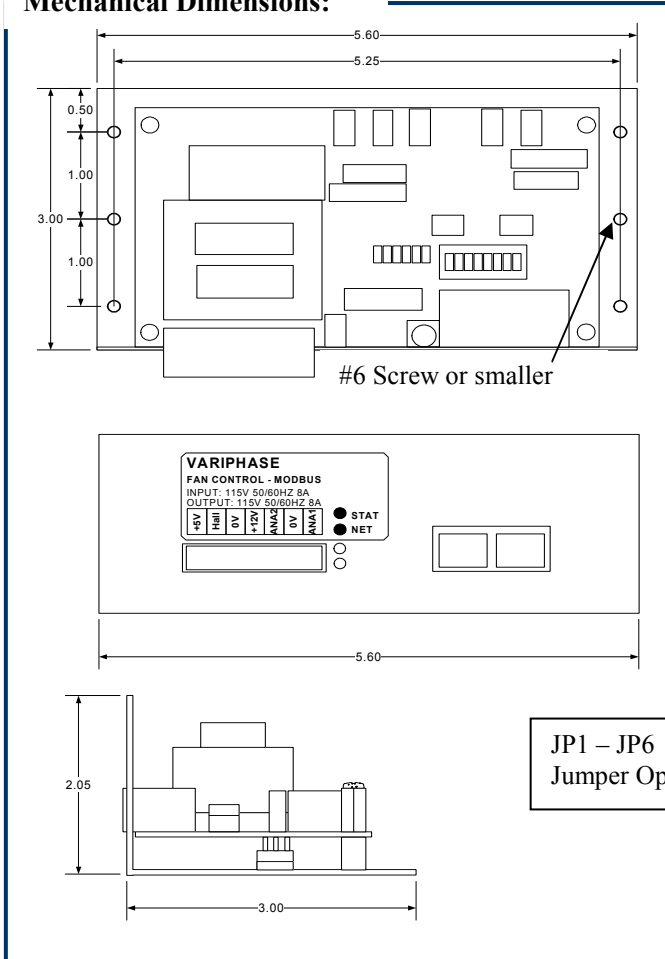

Important Wiring Information: Model ACV1083 does not have an internal fuse. The AC supply circuit must be externally fused with an approved 10ampere fuse or circuit breaker.

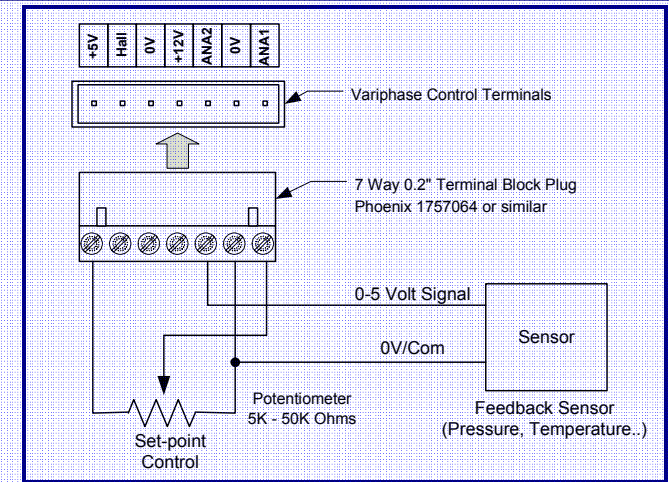

Control Wiring Example : Closed Loop Analog Control
In this mode VariPhase™ uses a 0-5 Volt feedback signal from a sensor to hold a potentiometer-controlled set-point. The set-point can also be network controlled. Enabling and configuring Closed Loop control requires an AirCare ACCI-SPI Console.

Control Connections

Mating part for control connector Phoenix terminal block number is #1757064

1	2	3	4	5	6	7
+5V Out	Hall Sensor Signal	0V (GND)	+12V Out	Analog 2 Input	0V (GND)	Analog Input

Power Connections

ML	AL	L	MN	N
Line in Motor	Line to Motor Aux	AV Line Input	Neutral to Motor	AC Neutral Input

