



### Installation

Because implementations vary, please read the relevant sections of this document thoroughly.

The recommended procedure for installing and configuring a Variphase system is:

Networked System	Non-networked System
Select appropriate Variphase Model based on Voltage and Current Requirements	Select appropriate Variphase Model based on Voltage and Current Requirements
Select 2-wire or 3-wire motor control model	Select 2-wire or 3-wire motor control model
Select Control Console – Available seperately from AirCare Automation Inc.	
Configure Option Jumpers	Configure Option Jumpers
Set each Variphase with a unique Modbus Address	Mount and Enclose Variphase
Mount and Enclose Variphase (see Page <b>Error! Bookmark not defined.</b> )	
Install Network Wiring	Install Control Wiring from Potentiometer or other analog source
Install Speed and/or Pressure Sensor if used (see application notes)	Install Speed Sensor (see application notes)
Install and check Power Wiring	Install and check Power Wiring
Power Up and Test	Power Up and Test

**Table 1**

### Additional Information for Networked Systems

For large systems, we recommend testing small sub-systems before completing full-scale installation.

In some systems additional RS485 devices may be needed to address offsets in ground voltage and ambient noise. Consult AirCare Automation for advice on RS485 network configuration.



### General Operation

#### Modes

Variphase operates in one of four selectable modes:

1. Networked Closed Loop
2. Networked Open Loop
3. Analog Closed Loop
4. Analog Open Loop

Closed loop operation requires a Hall-effect sensor to provide a tachometer signal. In this mode, Variphase will hold fan speed constant, even under varying load conditions. In networked mode it also allows the Controls to report speed in RPM to the AirCare Console. Modes are selected using Jumper Shunts JP1 and JP5.

An AirCare networked system requires a compatible Modbus host. In most cases this will be an AirCare Automation Console, but other Modbus devices can be used if configured correctly.

#### Option Jumpers

JP1	JP2	JP3	JP4	JP5	JP6
Analog	20mA	Baud	4-20mA	Closed Loop	4-Wire

**Table 2**

- Analog Install jumper to select analog input speed control from either 0-5V or 4-20mA sources. When jumper position is open, the control responds to Modbus speed commands.
- 20mA Install Jumper to enable current loop shunt. JP1 should also be closed to enable 4-20mA control. Leave switch open for 0-5V control.
- Baud Install jumper to select 9600 baud. Default is 1200.
- 4-20 Install jumper to enable 4-20mA loop. If jumper position is open, the 4mA offset will not be factored, resulting in a 0-20mA control range.
- Closed Loop Install jumper to enable closed loop control using an external sensor. The sensor will be used to regulate the set speed in RPM. If jumper position is open, the sensor input will not be used for motor speed control but, in network control mode, RPM will still be reported if a sensor is present.
- 4-Wire Fit Jumper to select 4-wire (RS422) communications. Default (jumper open) is 2-wire (RS485) communications.



## Address DIP Switches

Each Variphase in a network must be set to a unique address between 1 and 127. There are 8 switches on the DIP switch block of which switch 1-7 are used for addressing. Switch 8 should be left in the OFF position (not used for addressing). Address 0 is reserved for the Control Console (MODBUS master). The address DIP switches (1→7) are 'don't care' in Analog mode.

*Note: Option jumpers and address settings are only checked by the VariPhase controller at power-up, so power must be cycled before any changes take effect.*

## Compensation Tables

Variphase's memory contains tables data to linearize the relationship between set-point (from analog or network sources) and output. Modbus Register 22 selects which table is used for compensation. The default table (Table 0) provides a linear change in output voltage with an ideal load. Table 0 is suitable for most open-loop control applications.

Other tables can be selected to linearize for other output parameters, such as RPM. The tables are motor and application specific - contact AirCare Automation for further details.

## Troubleshooting

### LED Indicators

The NET Led shows all network activity (RS485 mode) or receive data activity (RS422 mode). With no bus activity this Led should be OFF.

If the NET Led is on-continuously, it is likely that the network connections are transposed (i.e. signals in the RS485 differential pair are swapped).

The STAT Led flashes steadily when the motor is stopped. When the motor is running, the STAT Led is on steadily. In addition, anytime the control responds to a Modbus message the Led flickers briefly.

### Diagnosing Other Faults

All Variphase models have an internal fuse. Excessive load current will cause the fuse to fault and the unit will be non-functional and non-responsive to network communications. The fuse is NOT field replaceable.



Electrical Wiring and Specifications

Electrical Ratings

Parameter	Min	Typical	Max
Input Voltage Range 115V unit (Vrms)	98V	115V	132V
Input Voltage Range 230V unit (Vrms)	195V	230V	264V
Input Voltage Range 277V unit (Vrms)	235V	277V	310V
Supply Frequency (Hz)		50/60Hz	
Output Current (Arms) 1.7A Models	-	-	1.7A (25°C)
Output Current (Arms) 1.7A Models	-	-	1.7A (40°C)
Output Current (Arms) 3A Model	-	-	3.0A (40°C)
Output Current (Arms) 4A Models	-	-	4.0A (40°C)
Output Current for 30 sec 1.7A Models	-	-	150%
Output Current for 30 sec 3-4A Models	-	-	125%
Output Voltage (Vac)	0	-	Vin
Ambient Operating Temperature (°C)	0	25°C	40°C
Standby Supply Power		< 2W	
Insertion Loss (V)		1V	
Control Power Loss (W)		1W / Amp	
Isolation Voltage (Vrms)	2500V		
Sensor Supply Voltage Output (Vdc)	4.8V	5.0V	5.2V
Sensor Supply Current Output (mA)			25mA

**Table 3**

Control Connections

1	2	3	4	5	6	7
+5V Out	Hall Sensor Signal	0V (GND)	- Network	+ Network	0V (GND)	Analog Input

**Table 4**

Mating Part for Control Connector : Phoenix 5.08mm Terminal Block Plug #1757064

Power Connections

ML	AL	L	MN	N
Line to Motor	Line to Motor Aux	AC Line Input	Neutral to Motor	AC Neutral Input

**Table 5**

Recommended Hall-Effect sensor: Cherry Part MP100701 or similar

### Power Wiring Diagram – 3 wire motor connection

Use this diagram with PSC motors for optimal efficiency and lowest noise.

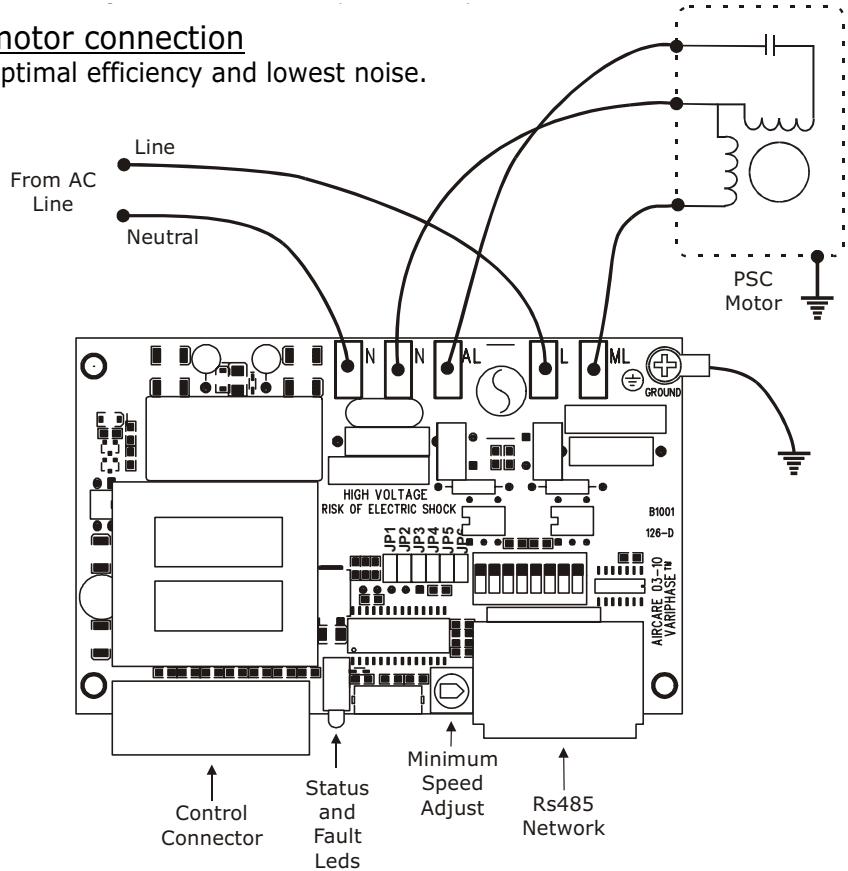

Figure 1

### Power Wiring Diagram – 2 wire Motor Connection

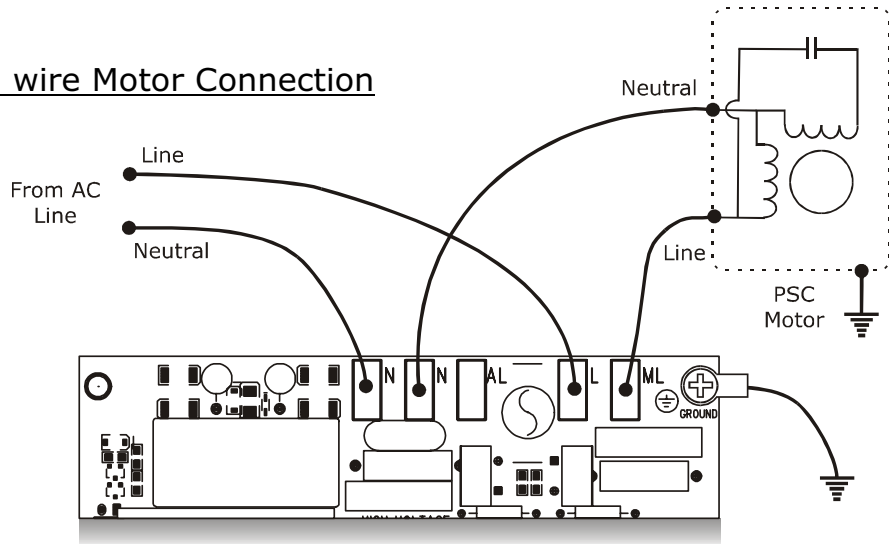
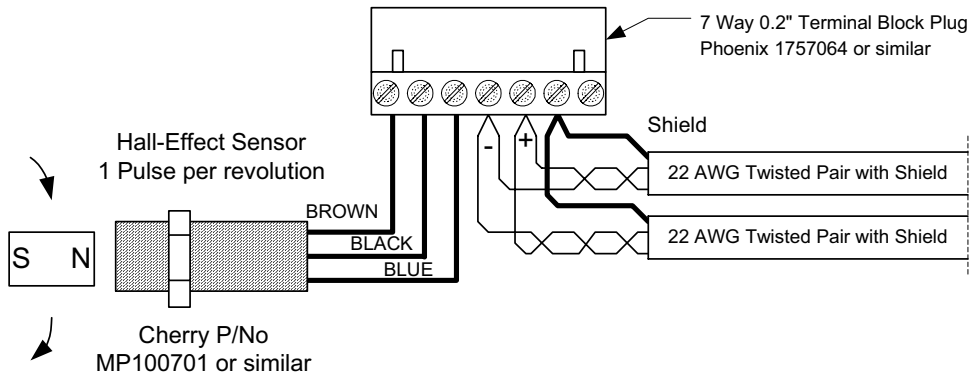
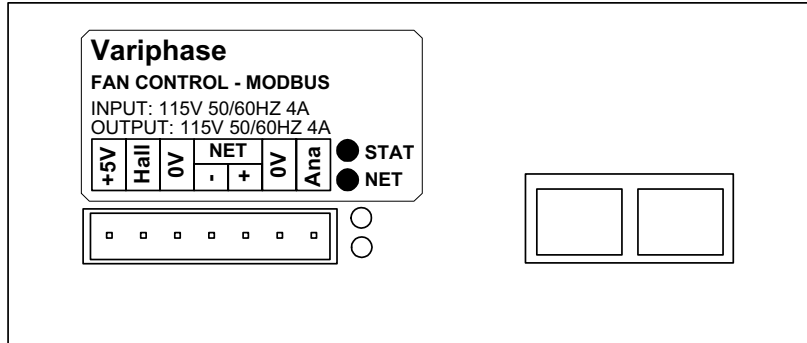

Figure 2

## Control Wiring Examples

OPTION JUMPERS
Analog : OFF
4-20mA : OFF
Baud : 1200 or 9600
20mA : OFF
Sensor : ON
4-Wire : OFF



### Closed Loop Network Control Wiring (Terminal Block network wiring shown)

OPTION JUMPERS
Analog : ON
4-20mA : OFF
Baud : Don't Care
20mA : OFF
Sensor : OFF
4-Wire : Don't care

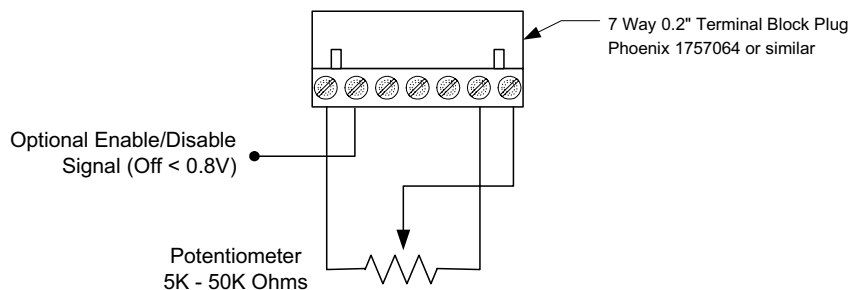
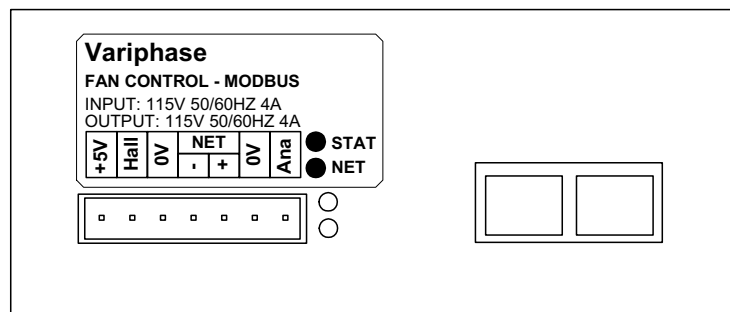

### Open Loop Potentiometer Control

Figure 3