

AirCare Automation Inc.



AirCare Interface Products

Intelligent Fan Control Solutions for

DC (GE-ECM) and

AC - 3ph (Invertek Drives)

ACM1004/1002 GE-ECM Interface Module

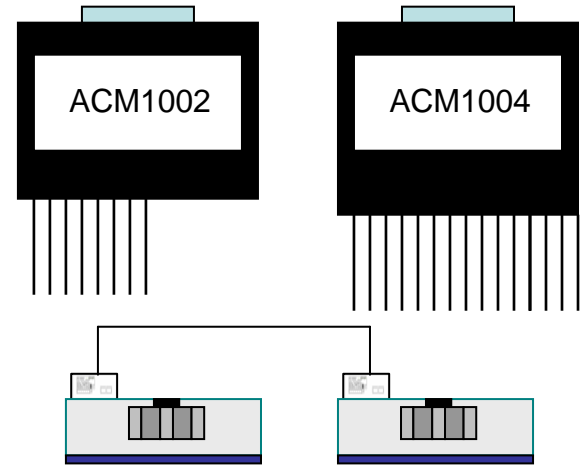

Motor Connections

Each motor is controlled with four wires. 5mm pitch screw terminal blocks are provided for board termination. The ACM 1002 will have 8 connections while the ACM1004 will have 16 connections available.

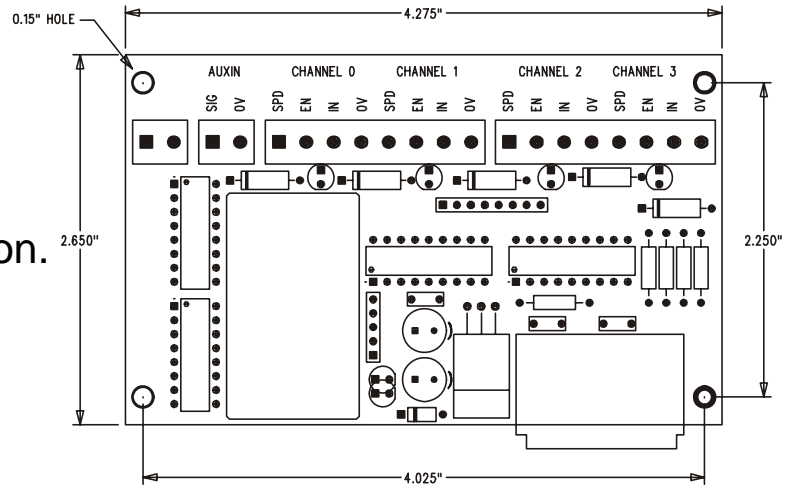

GE-ECM Motor Performance

AirCare Console and model 5sme3901

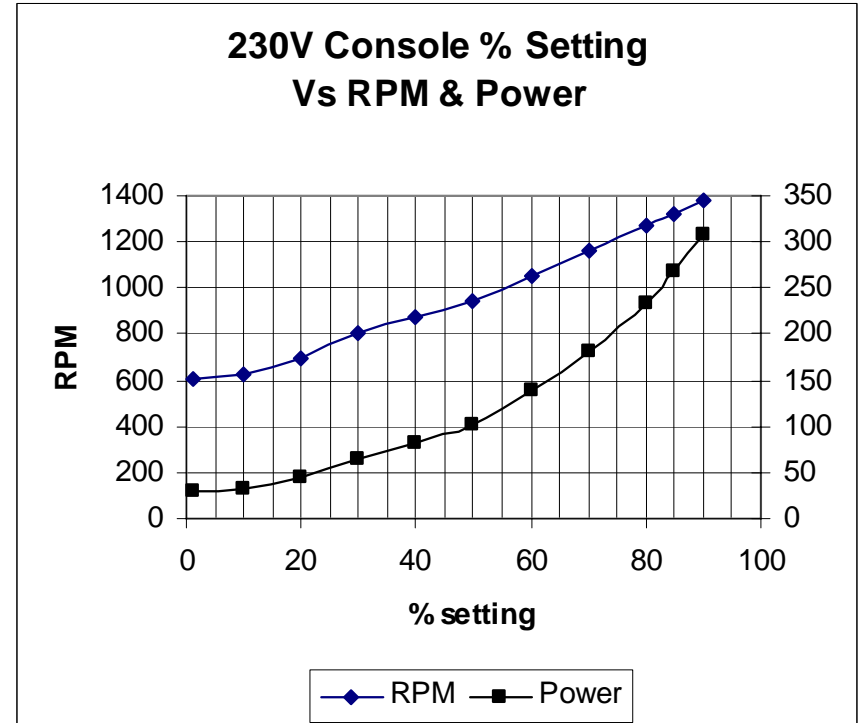
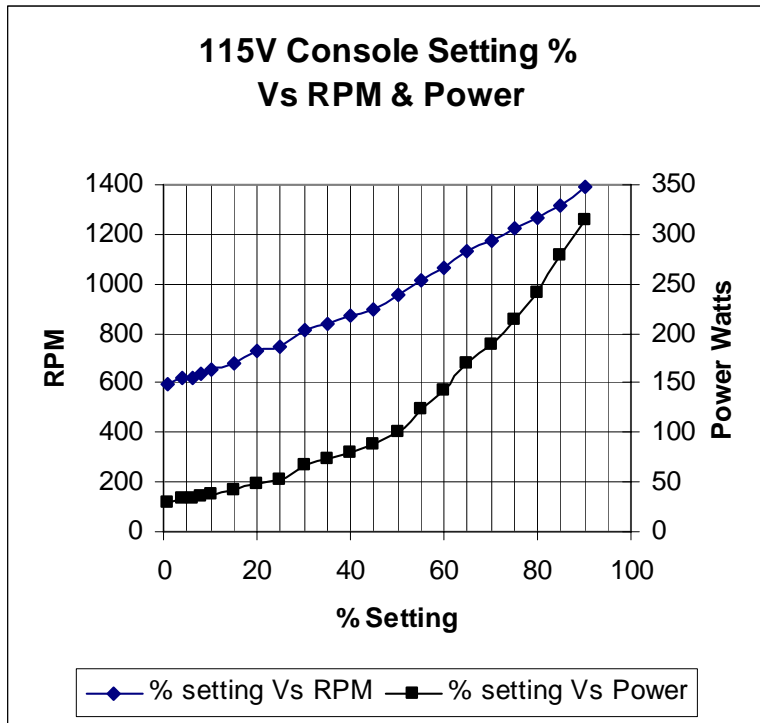

Two Ways to Power Your Zones

ACM1005

Wall Mount – Small System
One Way Power / Block
AC Adapter plug



ACM1008

Board Level – Multi-System
Adjustable Power / Block Nodes
Wire Connect mount

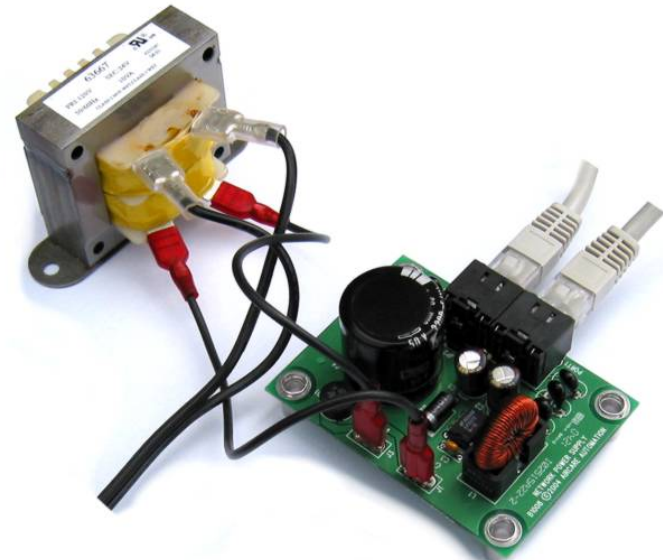

AirCare GE-ECM Small System

Flexibility and Function

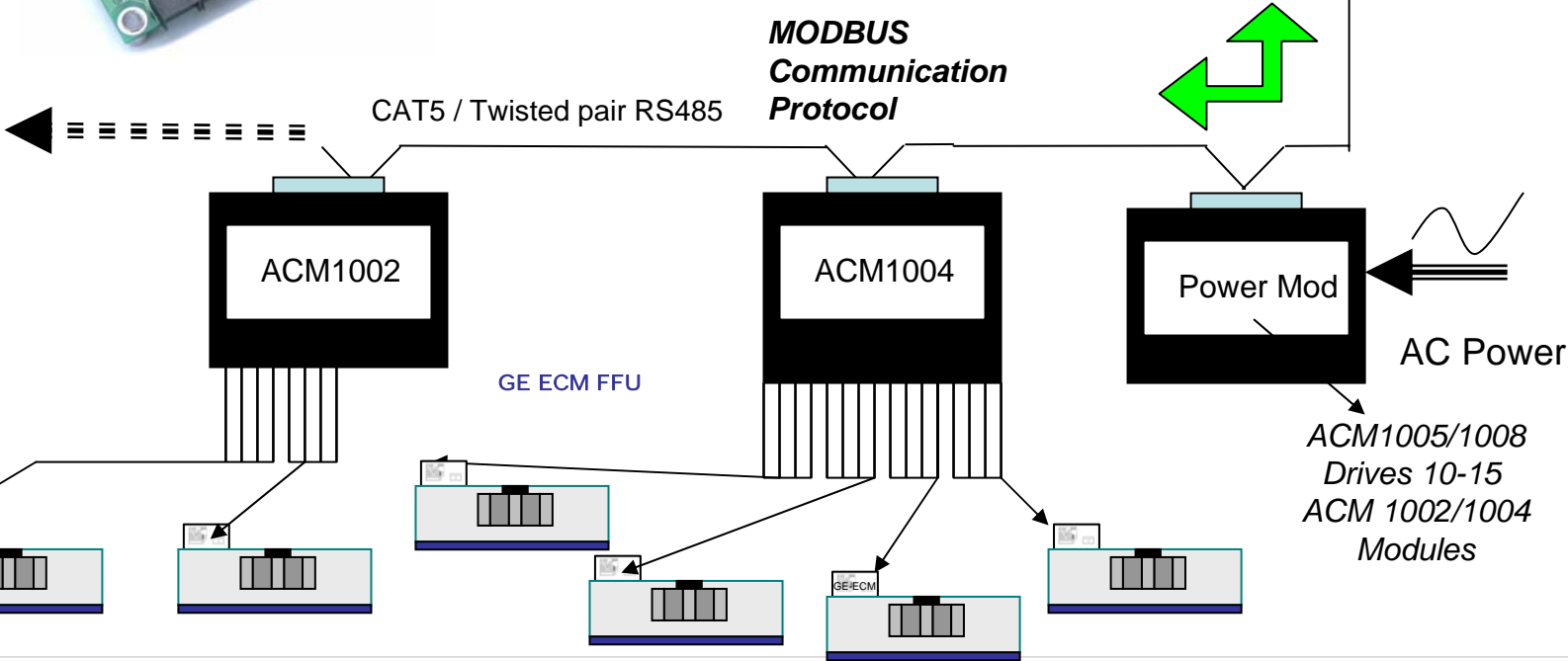
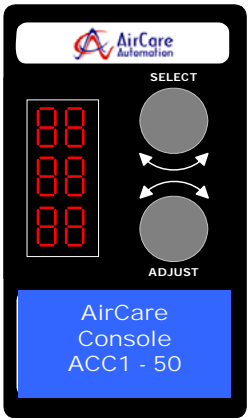
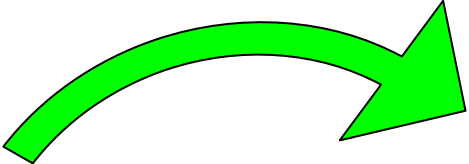

AirCare™ Small System GE-ECM Platform

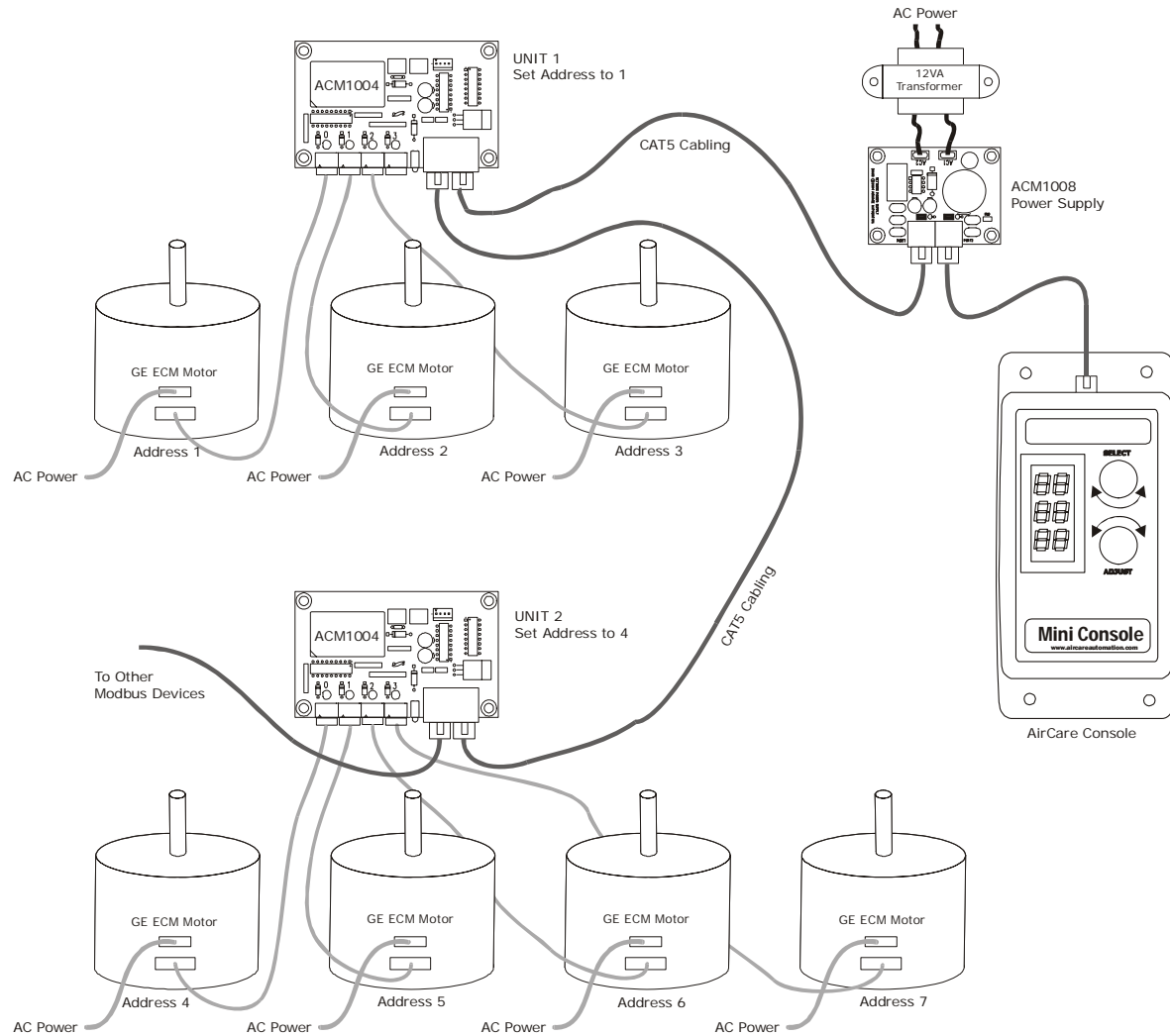

ACM1007 Remote High-Low Interface

The ACM1007 Interface allows remote control of an AirCare network's High-Low setting.

By adding an ACM1007 to a system, a remote switch or relay can signal high speed or low (set-back) speed to the AirCare Console.

Possible control devices include switches, timers, key-switches and building automation systems.



AirCare™ Small System Remote Set-Back

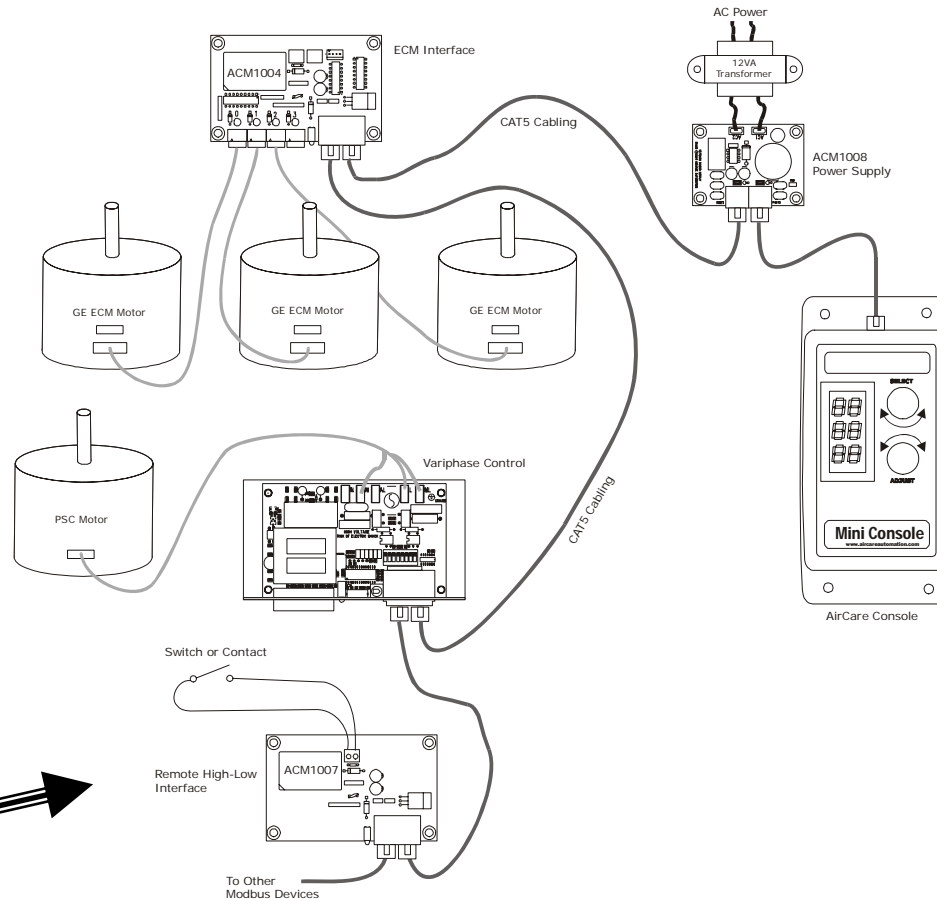

ACM1007



Invertek Drives Interface Module

- HVAC and other Industrial /commercial BAS requirements
- ACM1001 offers all Drive-> AirCare Console/PLC communications
- General Purpose Invertek OptiDrive Line fully compatible
- 3 Phase Inverter Drive Outputs to 200 HP
- Same MODBUS protocol as **AirCare Variphase™**
- Expanded range and robust full system support

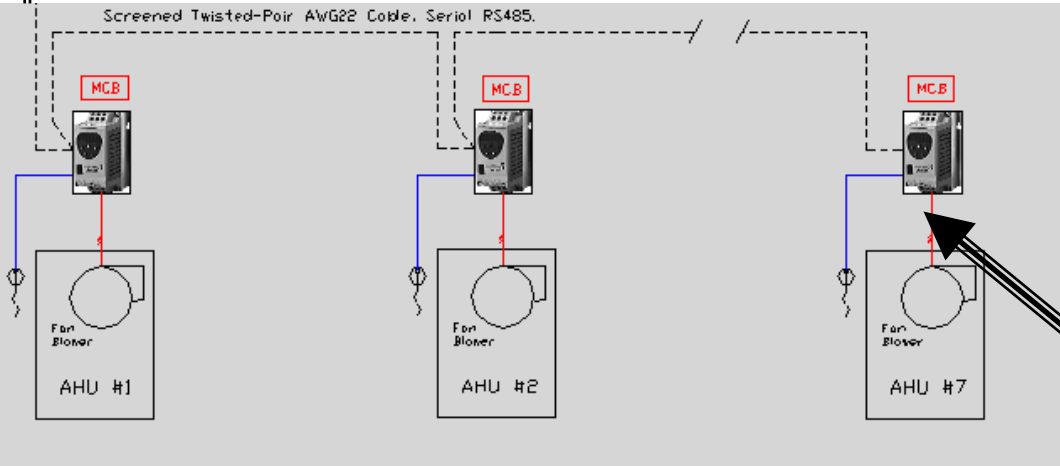
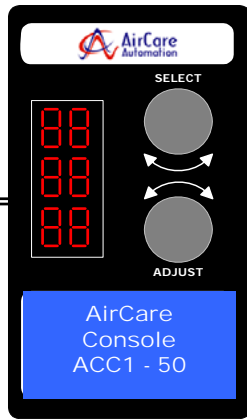

NEW!!!
ACM1001 now compatible with both
Invertek OptiDrive line and new
Invertek E-Drive line (selectable)

GE-ECM Small System Accessories



Enclosure for ACM1004-
Unit mounted on L-Bracket with cover
to provide NEMA1 enclosure

GE-ECM Cable Set – for 115V or 230V
Completed cables for interfacing the
Power and Control Sockets
of the GE-ECM Motor
to the AirCare Small System



AirCare Small System Demo

Evaluate and Demonstrate Small System Performance

Part# **ACMDEMO001**

- 1 - ACC1-10 (10 unit mini-console)**
- 2 - ACM1004 – GE-ECM Interface Modules**
- 4 – Interface cables for GE-ECM motor hook-up**
- 2 – CAT5 Patch Cables for system hook-up**

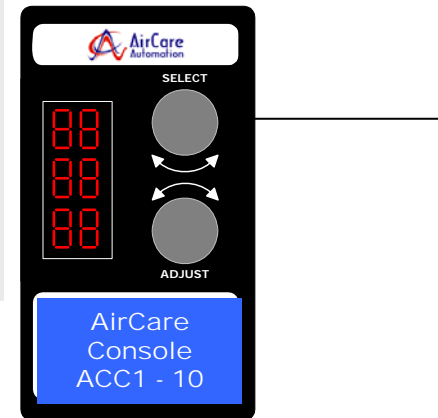

CAT5 / Twisted pair RS485

