

# GE-ECM Small System Control

*Intelligent Solutions for DC, GE-ECM Fan Control*

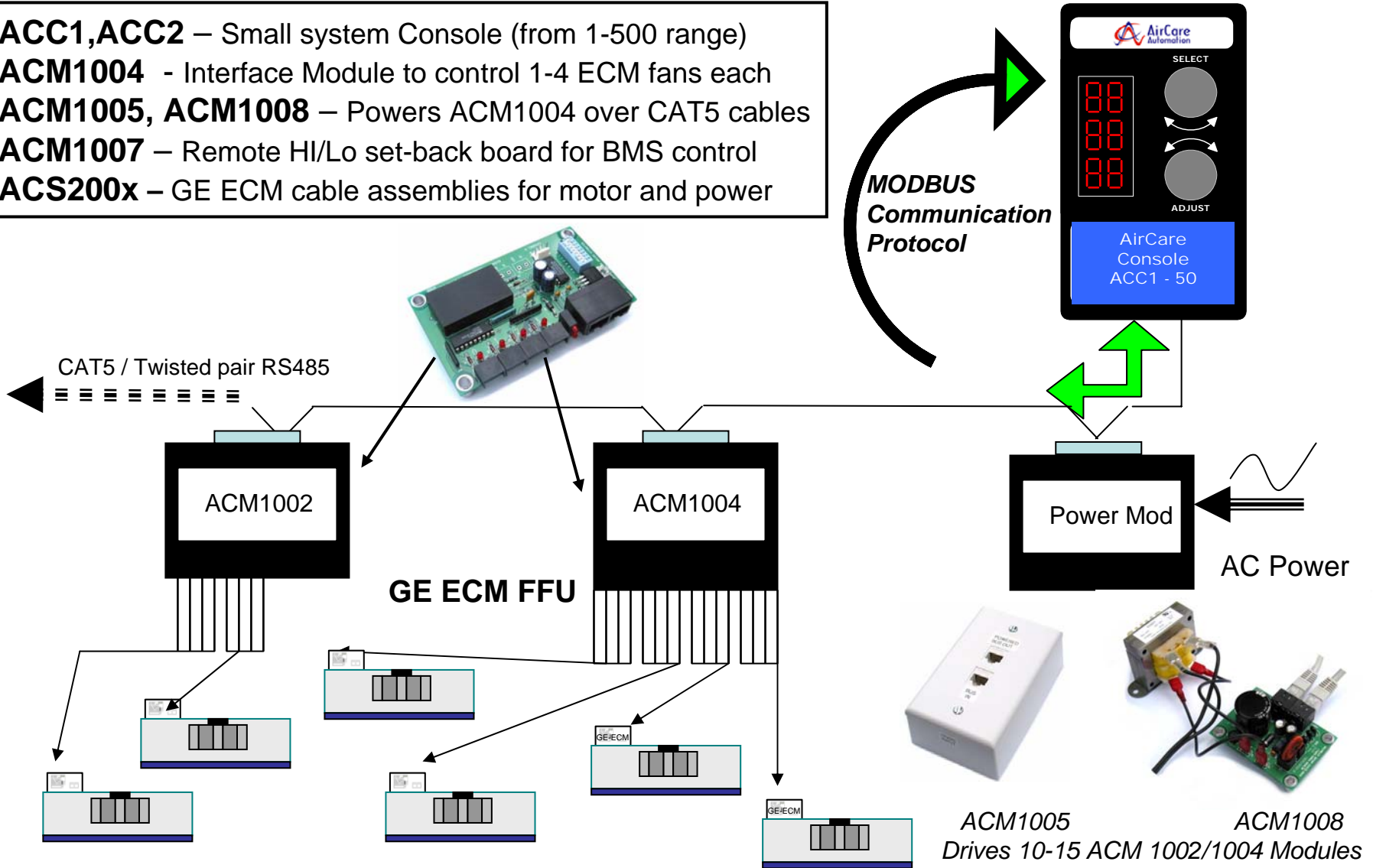

- ACC1, ACC2** – Small system Console (from 1-500 range)
- ACM1004** - Interface Module to control 1-4 ECM fans each
- ACM1005, ACM1008** – Powers ACM1004 over CAT5 cables
- ACM1007** – Remote HI/Lo set-back board for BMS control
- ACS200x** – GE ECM cable assemblies for motor and power



# GE ECM Motor Performance AirCare Console & GE - 5sme3901

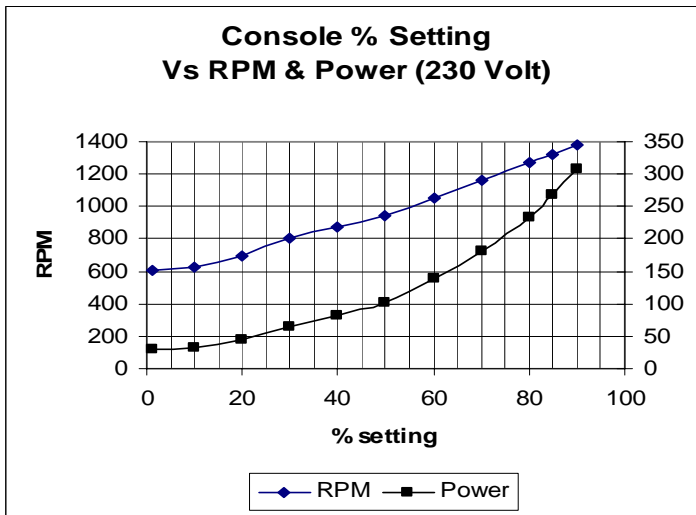
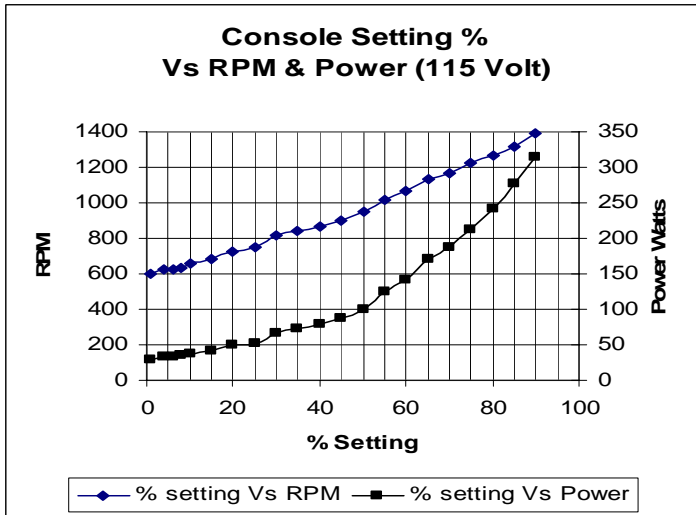

# AirCare™ Small System Remote Set-Back

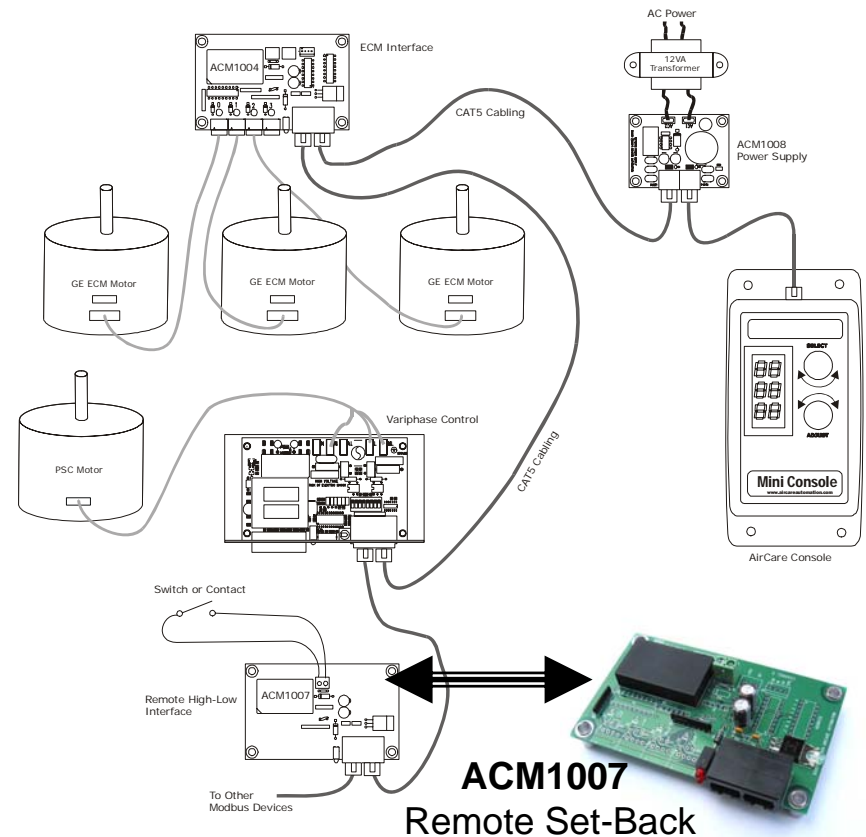

AirCare Automation, Inc. 8204 North Lamar Suite B11 Austin, TX 78753 U.S.A.

[www.aircareautomation.com](http://www.aircareautomation.com) Email: [info@aircareautomation.com](mailto:info@aircareautomation.com) Customer Service: 888-543-8037